

# Staying Alive as Cheaply as Possible

Patricia Bouyer<sup>1\*</sup>, Ed Brinksma<sup>2</sup>, and Kim G. Larsen<sup>3</sup>

<sup>1</sup> LSV – CNRS & ENS de Cachan – UMR 8643 – France  
Email: bouyer@lsv.ens-cachan.fr

<sup>2</sup> Department of Computer Science – University of Twente – The Netherlands  
Email: brinksma@cs.utwente.nl

<sup>3</sup> BRICS – Aalborg University – Denmark  
Email: kgl@cs.auc.dk

**Abstract.** This paper is concerned with the derivation of infinite schedules for timed automata that are in some sense optimal. To cover a wide class of optimality criteria we start out by introducing an extension of the (priced) timed automata model that includes both costs and rewards as separate modelling features. A precise definition is then given of what constitutes optimal infinite behaviours for this class of models. We subsequently show that the derivation of optimal non-terminating schedules for such double-priced timed automata is computable. This is done by a reduction of the problem to the determination of optimal mean-cycles in finite graphs with weighted edges. This reduction is obtained by introducing the so-called corner-point abstraction, a powerful abstraction technique of which we show that it preserves optimal schedules.

## 1 Introduction

In the past years the application of model-checking techniques to scheduling problems has become an established line of research. Scheduling problems can often be reformulated in terms of reachability, viz. as the (im)possibility to reach a state that improves on a given optimality criterion. Although there exists a wide body of literature and established results on (optimal) scheduling in the fields of real-time systems and operations research, the model-checking approach is interesting on two accounts. First of all, it serves as a benchmarking activity in which the effectivity and efficiency of model-checking can be compared to the best known results obtained by other techniques. Second, most classical scheduling solutions have good properties only in the context of additional assumptions that may or, quite often, may not apply in actual practical circumstances. Here model-checking techniques have the advantage of offering a generic approach for finding solutions in a model, in much the same way that, say, numerical integration techniques may succeed where symbolic methods fail.

Of course, model-checking comes with its own restrictions and stumbling blocks, the most notorious being the state-space explosion. A lot of research, therefore, is devoted to the containment of this problem by sophisticated techniques, such as data structures for compact state space representation, smart state space search strategies,

---

\* This work has been mostly done while visiting CISS at Aalborg University in Denmark and has been supported by CISS and by ACI Cortos, a program of the french ministry of research.

etc. An interesting idea for the model-checking of reachability properties that has received more attention recently is to somehow “guide” the exploration of the (symbolic) state space such that “promising” sets of states are visited first. In a number of applications [Feh99,HLP00,NY01,BMF02] model-checkers have been used to solve a number of non-trivial scheduling problems. Such approaches are different from classical, full state space exploration model-checking algorithms. They are used together with, for example, branch-and-bound techniques [AC91] to prune parts of the search tree that are guaranteed not to contain optimal solutions. This development has motivated research into the extension of model checking algorithms with optimality criteria. They provide a basis for the guided exploration of state spaces, and improve the potential of model-checking techniques for the resolution of scheduling problems. Work on extensions for application of the real-time model-checker Uppaal [LPY97,BLL<sup>+</sup>98] to optimal scheduling problems is reported in [BFH<sup>+</sup>01b,BFH<sup>+</sup>01a,LBB<sup>+</sup>01]; related work is reported in [AM99,ALTP01]. A closely related activity is reported in [AM01,AM02], where specific search algorithms on timed automata models are defined to solve classes of scheduling problems, such as job-shop and task graph scheduling.

The formulation of scheduling synthesis as a reachability problem is not accurate in cases of reactive behaviours, where actually an infinite (optimal) schedule must be determined in case of reactive behaviours. In this case, not the (optimal) reachability of a good *final* state, but the reachability of good (optimal) infinite behaviours is relevant. Borrowing terminology from performance analysis, we can say that we are interested in the *stationary* behaviours of the system. In the discrete case, stationary behaviours are cyclic behaviours. Assuming cyclic behaviour the cost of reaching a cycle will be insignificant compared to the infinite cost related to non-terminating cyclic behaviours (assuming a single cycle execution has some positive cost). Approximating infinite behaviours by finite ones can yield good and even optimal solutions if it is possible to search sufficiently “deep”, but costly pre-amble may also obscure limit optimal behaviours [Mad03].

In this paper we study optimal infinite behaviour in the context of *priced* timed automata<sup>4</sup>. In a discrete setting the detection of optimal behaviours goes back to Karp’s algorithm [Kar78], which determines the minimal mean cost of the cycles in a finite graph with weighted edges. Our contribution in this paper is that we show the computability of the corresponding symbolic question for priced timed automata using a reduction to a discrete problem *à la* Karp based on the so-called *corner-point abstraction*.

A second contribution is that we will not only establish computability of the problem in the original setting of priced timed automata [BFH<sup>+</sup>01b,BFH<sup>+</sup>01a,ALTP01], but also in an extension that features two price parameters, viz. *costs* and *rewards*. This is motivated by the fact that the optimality of infinite behaviours is usually expressed as a limit ratio between accumulated costs and rewards. In practical terms they may involve measures such as units of money, production, consumption, time, energy, etc., as in throughput (units/time), production cost (units/money), efficiency (units/energy), etc. In principle all of such measures could count both as cost and reward depending on

---

<sup>4</sup> Called *linearly priced timed automata* in [BFH<sup>+</sup>01b,BFH<sup>+</sup>01a,LBB<sup>+</sup>01] and *weighted timed automata* in [ALTP01].

the particular problem. In this paper the difference between cost and reward is merely a technical one: for infinite behaviour we insist that accumulated rewards diverge (tend to positive infinity), whereas the accumulation of cost has no such constraint. Optimality is then interpreted as maximizing or minimizing the cost/reward ratio.

The structure of the rest of this paper is as follows. In section 2 we define double-priced transition systems, and on that basis introduce the model of double-priced timed automata. Section 3 states the main technical result of the paper together with the assumptions that must be made. Section 4 introduces the central notion of corner-point abstraction related to the region automaton construction for timed automata. Section 5 contains the proof of a necessary result, which states that quotients of affine functions over regions (and more generally zones) attain their extreme values in corner points. In section 6 we show the corner-point abstraction to be sound, and in section 7 to be complete w.r.t. optimal behaviours. In section 8, finally, we draw our conclusions and give indications for future work.

For lack of space, proofs are not detailed in this article, but can be found in [BBL04].

## 2 Models and Problems

**Double-Priced Transition Systems.** A *Double-Priced Transition System* (DPTS for short) is a tuple  $(S, s_0, T, \text{cost}, \text{reward})$  where  $S$  is a set of states,  $s_0 \in S$  is the initial state,  $T \subseteq S \times S$  is the set of transitions, and  $\text{cost}, \text{reward} : T \rightarrow \mathbb{R}$  are price functions. If  $(s, s')$  is a transition then  $\text{cost}(s, s')$  and  $\text{reward}(s, s')$  are two *prices* (the cost and the reward) associated with the transition  $(s, s')$ . We shall use the notation  $s \rightarrow s'$  whenever  $(s, s') \in T$ , and  $s \xrightarrow{c,r} s'$  whenever  $(s, s') \in T$  with  $\text{cost}(s, s') = c$  and  $\text{reward}(s, s') = r$ .

Let  $\gamma = s_0 \rightarrow s_1 \cdots \rightarrow s_n$  be a finite execution of a DPTS  $(S, s_0, T, \text{cost}, \text{reward})$ . The price functions extend to  $\gamma$  in a natural way:

$$\text{Cost}(\gamma) = \sum_{k=1}^n \text{cost}(s_{k-1}, s_k) \quad \text{and} \quad \text{Reward}(\gamma) = \sum_{k=1}^n \text{reward}(s_{k-1}, s_k) .$$

Moreover, for a finite execution  $\gamma$  the *ratio*  $\text{Ratio}(\gamma)$  is defined as

$$\text{Ratio}(\gamma) = \frac{\text{Cost}(\gamma)}{\text{Reward}(\gamma)}$$

if this quotient does exist (*i.e.* if  $\text{Reward}(\gamma) \neq 0$ ). Now consider an infinite execution  $\Gamma$ . Denote by  $\Gamma_n$  the finite prefix of length  $n$  of  $\Gamma$ . The *ratio* of  $\Gamma$  is defined as

$$\text{Ratio}(\Gamma) = \lim_{n \rightarrow +\infty} \text{Ratio}(\Gamma_n)$$

provided this limit exists. Otherwise, we consider the *infimum ratio* and the *supremum ratio* (denoted respectively as  $\underline{\text{Ratio}}$  and  $\overline{\text{Ratio}}$ ) defined by

$$\underline{\text{Ratio}}(\Gamma) = \liminf_{n \rightarrow +\infty} (\text{Ratio}(\Gamma_n)) \quad \text{and} \quad \overline{\text{Ratio}}(\Gamma) = \limsup_{n \rightarrow +\infty} (\text{Ratio}(\Gamma_n)) .$$

Given a DPTS  $\mathcal{A}$ , we define the *optimal ratio*  $\mu_{\mathcal{A}}^*$  as

$$\mu_{\mathcal{A}}^* = \inf\{ \text{Ratio}(I) \mid I \text{ is an infinite execution of } \mathcal{A} \}$$

An infinite execution (also called *schedule*)  $I_{\mathcal{A}}^*$  of  $\mathcal{A}$  is *ratio-optimal* if  $\text{Ratio}(I_{\mathcal{A}}^*) = \mu_{\mathcal{A}}^*$ . Note that (for infinite-state DPTSs) a ratio-optimal run may not exist. In this case, we will say that  $(I_{\mathcal{A}}^{*,\varepsilon})_{\varepsilon>0}$  is a ratio-optimal family of runs whenever for every  $\varepsilon > 0$ ,  $|\text{Ratio}(I_{\mathcal{A}}^{*,\varepsilon}) - \mu_{\mathcal{A}}^*| < \varepsilon$ .

The *optimal ratio problem* consists then in computing  $\mu_{\mathcal{A}}^*$  and, if it does exist,  $I_{\mathcal{A}}^*$ , or a family  $(I_{\mathcal{A}}^{*,\varepsilon})_{\varepsilon>0}$ .

*Example 1.* Consider a DPTS with states  $\{A, B, C\}$  and transitions  $A \xrightarrow{1,1} B$ ,  $B \xrightarrow{1,0} B$ ,  $B \xrightarrow{2,1} C$ ,  $C \xrightarrow{1,0} B$ ,  $C \xrightarrow{2,1} C$  and  $C \xrightarrow{1,1} A$ , and with  $A$  initial state. To see that the ratio is not always defined consider the execution  $B \rightarrow C \rightarrow B^2 \rightarrow C^2 \rightarrow B^4 \rightarrow C^4 \rightarrow \dots \rightarrow B^{2^n} \rightarrow C^{2^n} \dots$ . Computing ratios of finite prefixes, we get respectively

$$\begin{aligned} \text{Ratio}(B \rightarrow C \rightarrow B^2 \rightarrow C^2 \rightarrow \dots \rightarrow B^{2^n}) &= 3 \\ \text{whereas } \text{Ratio}(B \rightarrow C \rightarrow B^2 \rightarrow C^2 \rightarrow \dots \rightarrow B^{2^n} \rightarrow C^{2^n}) &= 5 \end{aligned}$$

On the other hand, the execution consisting in an infinite repetition of the cycle  $A \rightarrow B \rightarrow C \rightarrow A$  has a well-defined ratio,  $\frac{4}{3}$ , which is in fact the optimum ratio of the given DPTS.  $\square$

**Double-Priced Timed Automata.** For *finite-state* DPTSs the optimal ratio  $\mu^*$  is obviously computable. Karp's Theorem [Kar78] provides an algorithm with time complexity  $\mathcal{O}(V.E)$  ( $V$  being the number of states and  $E$  the number of edges) in the case that the reward of each transition is 1. Extensions of Karp's algorithm have been proposed for computing  $\mu^*$  in the general case, see for example [DG98,DIG99]. In the remainder of this paper we shall settle the computability of  $\mu^*$  for *infinite-state* DPTS derived from so-called double-priced timed automata being timed automata extended with price(-rates) for determining cost and reward of discrete and delay transitions.

Given a set of clocks  $X$ , the set of clock constraints  $\mathcal{C}(X)$  is defined inductively by the following rules:

$$g ::= x \bowtie c \mid g \wedge g$$

where  $x \in X$ ,  $c \in \mathbb{N}$  and  $\bowtie \in \{<, \leq, =, \geq, >\}$ .

**Definition 1.** A Double-Priced Timed Automaton (*DPTA for short*) over a set of clocks  $X$  is a tuple  $(L, \ell_0, E, I, c, r)$ , where  $L$  is a finite set of locations,  $\ell_0$  is the initial location,  $E \subseteq L \times \mathcal{C}(X) \times 2^X \times L$  is the set of edges<sup>5</sup>,  $I : L \rightarrow \mathcal{C}(X)$  assigns invariants to locations and  $c, r : (L \cup E) \rightarrow \mathbb{Z}$  assign price-rates to locations and prices to edges.

<sup>5</sup> In case  $(\ell, g, r, \ell') \in E$ , we write  $\ell \xrightarrow{g,r} \ell'$ .

*Example 2.* Consider a production system consisting of a number of machines  $M_1, \dots, M_n$  all attended to by a single operator  $O$ . Each machine  $M_i$  has two production modes: a *high* ( $H$ ) and a *low* ( $L$ ) mode, characterized by the amount of goods produced per time-unit ( $G$  respectively  $g$ ) and the amount of power consumed per time-unit ( $P$  respectively  $p$ ). From the producers point of view the *high* production mode is preferable as it has a better (*i.e.* smaller)  $P/G$ -ratio than the *low* production mode. Unfortunately, each machine can only operate in the *high* production mode for a certain amount of time ( $D$ ) without being attended to by the operator. The operator, in turn, needs a minimum time-separation ( $S$ ) between attending machines. The figure on the right provides DPTA's for a typical machine and an operator.<sup>6</sup>In Fig. 1 we consider a production system obtained as the product of a machine  $M_1$  with parameters  $D = 3, P = 3, G = 4, p = 5, g = 2$ , a machine  $M_2$  with parameters  $D = 6, P = 3, G = 2, p = 5, g = 2$  and a single operator with separation time  $S = 4$ . In the product construction a cost (reward) rate of a composite location is obtained as sum of the cost (reward) rates of the corresponding component locations.  $\square$

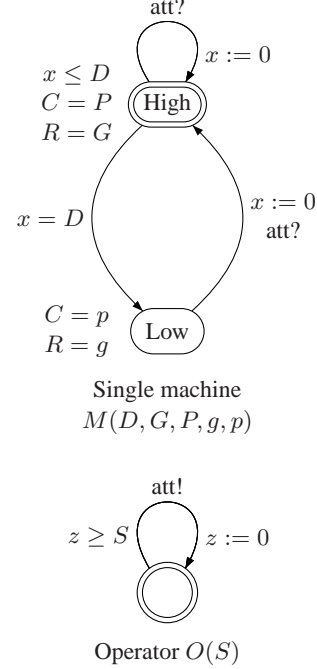

The semantics of a DPTA is given as a DPTS. Intuitively, there are two types of transitions: delay transitions with cost and reward obtained by applying the rates  $c$  and  $r$  of the source location, and discrete transitions with cost and reward given by the values of  $c$  and  $r$  of the corresponding edge. Before formally stating the semantics, we introduce a few definitions. A clock valuation  $u \in \mathbb{R}_{\geq 0}^X$  is a function which assigns values to clocks. If  $d \in \mathbb{R}_{>0}$  is a delay, then  $u + d$  denotes the clock valuation such that for each clock  $x$ ,  $(u + d)(x) = u(x) + d$ . If  $r$  is a set of clocks then  $[r \leftarrow 0]u$  is the clock valuation  $u'$  with  $u'(x) = 0$  if  $x \in r$  and  $u'(x) = u(x)$  otherwise. Finally we write  $u \models g$  if and only if the clock valuation  $u$  satisfies the guard  $g$  (defined in the natural way).

**Definition 2.** *The semantics of a DPTA  $\mathcal{A} = (L, \ell_0, T, I, c, r)$  over set of clocks  $X$  is the DPTS  $(S, s_0, \longrightarrow, \text{cost}, \text{reward})$  over  $X$ , where  $S = L \times \mathbb{R}_{\geq 0}^X$ ,  $s_0 = (\ell_0, \mathbf{0})$  (where  $\mathbf{0}$  assigns 0 to each clock of  $X$ ), and  $\longrightarrow$  is defined as follows:*

- $(\ell, u) \xrightarrow{c, r} (\ell, u + d)$  if  $u + t \models I(\ell)$  for every  $0 \leq t \leq d$ ,  $c = c(\ell) \cdot d$  and  $r = r(\ell) \cdot d$
- $(\ell, u) \xrightarrow{c, r} (\ell', u')$  if there exists a transition  $\ell \xrightarrow{g, r} \ell'$  in  $T$  such that  $u \models g$ ,  $u' = [r \leftarrow 0]u$ ,  $u' \models I(\ell')$ ,  $c = c(\ell \xrightarrow{g, r} \ell')$ , and  $r = r(\ell \xrightarrow{g, r} \ell')$ .

<sup>6</sup> The cost and reward rates are both zero in the single location of the Operator.

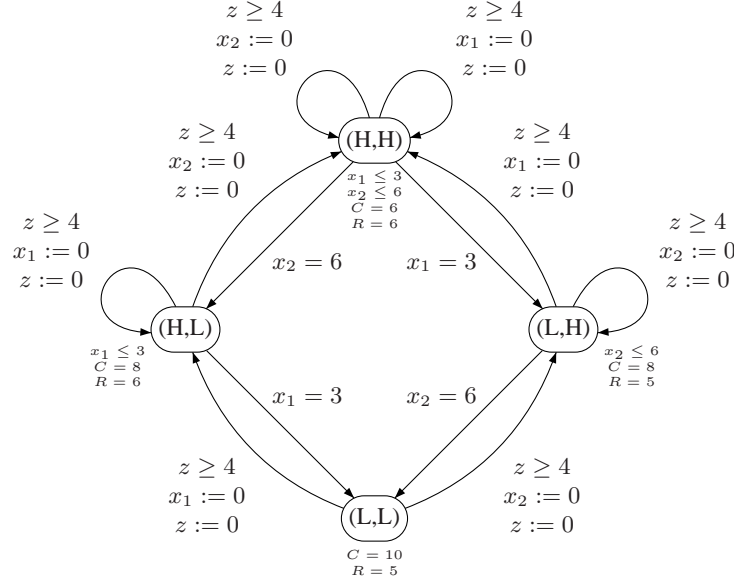

**Fig. 1.** Production System with Two Machines  $M(D = 3, P = 3, G = 4, p = 5, g = 3)$  and  $M(D = 6, P = 3, G = 2, p = 5, g = 2)$  and an Operator  $O(4)$ .

*Example 3.* Reconsider the Production System from Fig. 1. The following is an infinite execution providing a scheduling policy for the operator with the cost-reward ratio  $96/66 \approx 1,455$ :

$$\begin{aligned}
 & ((H, H), x_1 = x_2 = z = 0) \xrightarrow{18,18} ((L, H), x_1 = x_2 = z = 3) \xrightarrow{8,5} \\
 & ((L, H), x_1 = x_2 = z = 4) \longrightarrow ((H, H), x_1 = z = 0, x_2 = 4) \quad (*) \xrightarrow{12,12} \\
 & ((H, L), x_1 = z = 2, x_2 = 6) \xrightarrow{8,6} ((L, L), x_1 = z = 3, x_2 = 7) \xrightarrow{10,5} \\
 & ((L, L), x_1 = z = 4, x_2 = 8) \longrightarrow ((H, L), x_1 = z = 0, x_2 = 8) \xrightarrow{24,18} \\
 & ((L, L), x_1 = z = 3, x_2 = 11) \xrightarrow{10,5} ((L, L), x_1 = z = 4, x_2 = 12) \longrightarrow \\
 & ((L, H), x_1 = 4, x_2 = z = 0) \xrightarrow{32,20} ((L, H), x_1 = 8, x_2 = z = 4) \\
 & \longrightarrow ((H, H), x_1 = z = 0, x_2 = 4) \quad (*)
 \end{aligned}$$

Fig. 2(a) illustrates this schedule as a Gantt chart. An other execution providing a scheduling policy with the cost-reward ratio  $68/46 \approx 1,478$  is given in Fig. 2(b).  $\square$

*Remark.* Let us point out several interesting subclasses of DPTAs. The reward will be said *impulse-based* whenever all reward-rates in locations are zero. This class corresponds roughly to the *mean* ratio as in classical finite-state systems [DIG99]. An other interesting class is the one where the reward corresponds to the elapsing of time, that is when all location reward-rates are 1 and all transition rewards are 0. This last class corresponds to the usual intuitive notion of stationary behaviours where the measure is the cost by unit of time.

### 3 Result

**Restrictions.** In the remainder of this paper, we do several restrictions on the models we consider. We first restrict ourselves to reward functions that are non-negative. We

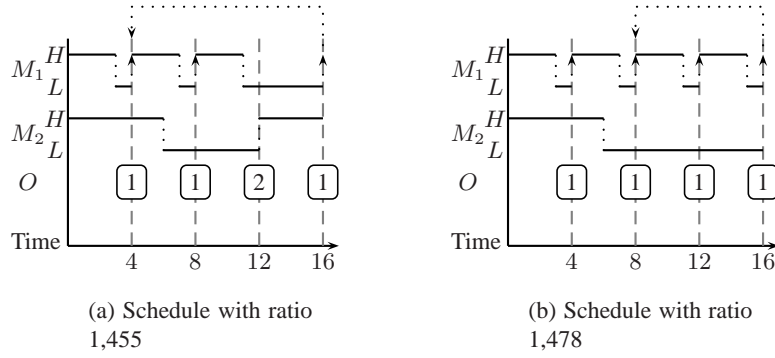
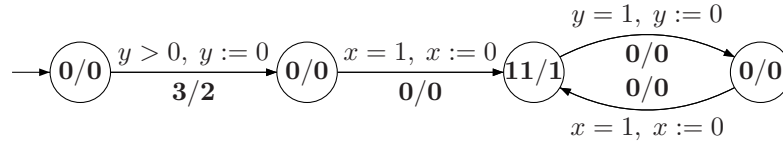

**Fig. 2.** Schedules for the Production System with ratios 1,455 and 1,478.

also restrict ourselves to double-priced timed automata where the reward is *strongly reward-diverging* in the following sense:

A DPTA  $\mathcal{A}$  is *strongly reward-diverging* if, closing all the constraints of  $\mathcal{A}$  (that is replacing in  $\mathcal{A}$  each constraint  $x < c$  by  $x \leq c$  and each constraint  $x > c$  by  $x \geq c$ ), every infinite path  $\Gamma$  of the new *closed* automaton should satisfy that  $\text{Reward}(\Gamma) = +\infty$ .

*Example 4.* The following DPTA does not meet the previous restriction. Indeed consider the path  $\gamma_{n,d}$  that takes the first transition at date  $d$  and then takes  $n$  times the loop. We have that  $\text{Reward}(\gamma_{n,d}) = 2 + d.n$ . Thus, the ratio of any real infinite path is  $+\infty$  (because for those states  $d$  is positive). Now, if we consider the infinite path where  $d$  is 0 (this path is a path of the automaton where all constraints have been closed), we get that  $\text{Reward}(\gamma_{n,0}) = 2 \neq +\infty$ .



Notice that this restriction implies in particular that all executions in timed automata we consider are *non-zero* because the reward is in  $\mathcal{O}(\text{time elapsed})$ . As we will see later, this assumption will have an other important implication, see Proposition 2.

**Assumption for the following.** We assume that timed automata are *bounded*, that is there exists a constant  $M$  such that for every reachable extended state  $(\ell, v)$ , for every clock  $x$ ,  $v(x) \leq M$ . This is not a restriction as every DPTA can be transformed into an “equivalent” bounded timed automaton (strongly bisimilar and with the same costs and rewards).

We can now state the main result of this paper.

**Theorem 1.** *The optimal ratio problem is computable for strongly reward-diverging DPTAs with non-negative rewards.*

A more precise statement of the above theorem is obtained by notions of *soundness* and *completeness*. Given two DPTSs  $\mathcal{S}$  and  $\mathcal{S}'$  we say that  $\mathcal{S}'$  is *sound* w.r.t  $\mathcal{S}$  whenever  $\mu_{\mathcal{S}'}^* \leq \mu_{\mathcal{S}}^*$  and we say that  $\mathcal{S}'$  is *complete* w.r.t.  $\mathcal{S}$  whenever  $\mu_{\mathcal{S}}^* \leq \mu_{\mathcal{S}'}^*$ . Theorem 1 is now a corollary of the following Proposition:

**Proposition 1.** *Let  $\mathcal{A}$  be a bounded and strongly reward-diverging DPTA with non-negative rewards. Then there exists a finite-state DPTS  $\mathcal{S}$  which is sound and complete w.r.t. the DPTS defined by  $\mathcal{A}$ .*

The finite-state DPTS we will prove sound and complete w.r.t. to a bounded DPTA  $\mathcal{A}$  is the so-called *corner-point abstraction* of  $\mathcal{A}$  that we define in the next section.

## 4 Regions and Corner-Point Abstraction

The aim of this section is to propose a discretization of timed automata behaviours based on an extension of the region automaton construction [AD90,AD94]. We fix a DPTA  $\mathcal{A}$  and we assume that it is bounded by  $M$ . Moreover, we denote by  $k$  its number of clocks.

**Regions and Corner-Points.** In this paper, we will use the standard notion of regions, as initially defined by Alur and Dill [AD90]. As we consider only bounded timed automata, we only need bounded regions. A *region* (bounded by  $M$ ) over a (finite) set of clocks  $X$  is a tuple  $r = (h, [X_0, \dots, X_p])$  where  $h : X \rightarrow \mathbb{N} \cap [0, M]$  assigns to each clock an integer value between 0 and  $M$ ,  $p$  is some integer, and  $(X_i)_{i=0, \dots, p}$  forms a partition of  $X$  such that for all  $i > 0$ ,  $X_i \neq \emptyset$  and  $h(x) = M$  implies  $x \in X_0$ .

Given a valuation  $v$ , we say that  $v$  is in the region  $r$  whenever:

- for any clock  $x \in X$ , the integer part of  $v(x)$  is  $h(x)$ ,
- for any clock  $x$ ,  $x \in X_0 \iff v(x) = h(x)$ ,
- for all clocks  $(x, y)$ ,  $\{v(x)\} \leq \{v(y)\} \iff x \in X_i$  and  $y \in X_j$  with  $i \leq j$ .

where  $\{\cdot\}$  represents the fractional part.

A(n  $M$ -)corner-point is an element  $\alpha = (a_j)_{1 \leq j \leq k}$  of  $\mathbb{N}^k$  such that for every  $1 \leq j \leq k$ ,  $0 \leq a_j \leq M$ . Let  $R$  be a region. A corner-point  $\alpha$  is associated with  $R$  whenever it is in the closure of  $R$  (for the usual topology of  $\mathbb{R}^k$ ). Let  $r = (h, [X_0, \dots, X_p])$  be a region. It has  $p + 1$  corner-points,  $(\alpha_i)_{0 \leq i \leq p}$ , such that:

$$\alpha_i(x) = \begin{cases} h(x) & \text{if } x \in X_j \text{ with } j \leq i \\ h(x) + 1 & \text{if } x \in X_j \text{ with } j > i \end{cases}$$

**Corner-Point Abstraction.** We will construct a finite state DPTS  $\mathcal{A}_{cp}$  called the *corner-point abstraction* of  $\mathcal{A}$  where states are of the form  $(\ell, R, \alpha)$  with  $\ell$  being a location,  $R$  a region and  $\alpha$  a corner-point of  $R$ . Transitions of  $\mathcal{A}_{cp}$  are defined in the following manner:



*Discrete transitions.* If  $e = \ell \xrightarrow{g,r} \ell'$  is a transition of  $\mathcal{A}$ , there will be transitions  $e' = (\ell, R, \alpha) \longrightarrow (\ell', R', \alpha')$  in  $\mathcal{A}_{\text{cp}}$  with  $R \subseteq g$ ,  $R' = [r \leftarrow 0]R$ ,  $\alpha$  corner-point associated with  $R$ ,  $\alpha'$  corner-point associated with  $R'$  and  $\alpha' = [r \leftarrow 0]\alpha$ . We set  $\text{cost}(e') = \text{cost}(e)$  and  $\text{reward}(e') = \text{reward}(e)$ .

*Idling transitions.* There are two types of idling transitions.

- There are transitions  $e' = (\ell, R, \alpha) \longrightarrow (\ell, R, \alpha')$  whenever  $\alpha$  and  $\alpha'$  are distinct corner-points of  $R$  and  $\alpha'$  is the time successor of  $\alpha$  (in which case,  $\alpha' = \alpha + 1$ ). We set  $\text{cost}(e') = \text{cost}(\ell)$  and  $\text{reward}(e') = \text{reward}(\ell)$  (intuitively the delay between the corner-points is precisely one time unit).
- There are transitions  $e' = (\ell, R, \alpha) \longrightarrow (\ell, R', \alpha)$  whenever  $R'$  is the time successor region of  $R$  and  $\alpha$  is a corner-point associated with both  $R$  and  $R'$ . We set  $\text{cost}(e') = 0$  and  $\text{reward}(e') = 0$

The following proposition is an important consequence of the strongly reward-divergence hypothesis.

**Proposition 2.** *Let  $\mathcal{A}$  be a bounded, strongly reward-diverging DPTA with non-negative rewards. Then there exist two constants  $\lambda > 0$  and  $\mu \geq 0$  such that for any infinite path  $\Pi$  of  $\mathcal{A}_{\text{cp}}$*

$$\text{Reward}(\Pi_n) \geq \lambda \cdot n - \mu$$

where  $\Pi_n$  denotes the prefix of length  $n$  of  $\Pi$ .

Note that the above  $\lambda$  and  $\mu$  only depend on the automaton  $\mathcal{A}$ , not on the paths.

Let  $\gamma : (\ell_0, u_0) \longrightarrow (\ell_1, u_1) \longrightarrow \dots$  be a real (finite or infinite) path in  $\mathcal{A}$ . The set of all paths

$$\pi : (\ell_0, R_0, \alpha_{0,0}) \longrightarrow (\ell_0, R_0, \alpha_{0,1}) \dots (\ell_0, R_0, \alpha_{0,p_0}) \longrightarrow (\ell_1, R_1, \alpha_{1,0}) \dots$$

in  $\mathcal{A}_{\text{cp}}$  such that for every  $i$ ,  $u_i \in R_i$  and for every  $j$ ,  $\alpha_{i,j}$  is a corner-point associated with  $R_i$  is denoted  $\text{proj}_{\text{cp}}(\gamma)$ . Note that if  $\gamma : (\ell_0, u_0) \longrightarrow (\ell_1, u_1) \longrightarrow \dots$  and  $\gamma' : (\ell_0, v_0) \longrightarrow (\ell_1, v_1) \longrightarrow \dots$  are two “region-equivalent” real-paths (*i.e.* for every  $i$ ,  $u_i$  and  $v_i$  are region-equivalent), then  $\text{proj}_{\text{cp}}(\gamma) = \text{proj}_{\text{cp}}(\gamma')$ .

In the remainder of the paper, we will prove that the optimal ratio of the corner-point abstraction is the same as the optimal ratio of the original DPTA. As the corner-point abstraction can be effectively constructed and as computing optimal ratios in finite-state DPTSs (the corner-point abstraction is a finite-state DPTS) is effective (see for example [Kar78,DG98,DIG99]), we get that  $\mu_{\mathcal{A}}^*$  is effectively computable for DPTAs  $\mathcal{A}$  satisfying the strongly reward-divergence hypothesis.

*Example 5.* If we come back to the automaton of Example 4, as we have already seen, it does not meet the strongly reward-divergence restriction. It is easy to compute that for any real infinite path  $\Gamma_d$  (where  $d$  denotes the date the first transition is taken),  $\text{Ratio}(\Gamma_d) = 11$ . However if we consider the path  $\Pi$  of the corner-point abstraction where  $d$  would be 0, we get that  $\text{Ratio}(\Pi) = \frac{3}{2}$ . We see that we could change the costs and rewards on the transitions, and we would get that there is no relation between the ratio of paths in the original automaton and ratio of paths in the corner-point abstraction. This shows that strongly reward-divergence is necessary.

## 5 Quotient of Affine Functions

This section contains technical results that will be useful in the following. Let  $A$  be a closed set. The *border* of  $A$  is denoted by  $\text{Border}_n(A)$  and is defined as  $A \setminus \overset{\circ}{A}$  where  $\overset{\circ}{A}$  denotes the interior of  $A$ . Let  $A$  be a closed set and  $x$  a point in  $\mathbb{R}^n$ . The following statements are equivalent and characterize the border of  $A$ :

- $x \in \text{Border}_n(A)$
- $x \in A$  and for every  $\varepsilon > 0$ , there exists  $y \notin A$  such that  $\|x - y\|_\infty < \varepsilon$ .<sup>7</sup>

The proofs of the two following lemmas can be found in the appendix.

**Lemma 1.** *Let  $f$  be a function defined on a compact convex set  $A \subset \mathbb{R}^n$  (where  $n \geq 1$ ) such that*

$$f(x_1, \dots, x_n) = \frac{\sum_{i=1}^n c_i x_i + c}{\sum_{i=1}^n r_i x_i + r}$$

*We assume in addition that  $A$  is included in the definition set of  $f$ . Then the minimum of  $f$  on  $A$  is obtained on the border of  $A$ .*

In the remainder of the section, we will use the standard notion of zone. A *zone* over the set of clocks  $X$  is a **convex** set of valuations defined by constraints of the forms  $x \bowtie c$  and  $x - y \bowtie c$  where  $x$  and  $y$  are in  $X$ ,  $\bowtie \in \{\leq, <, =, >, \geq\}$  and  $c$  is an integer. For example, the constraints  $\{x \leq 3, y \geq 4, x - y < -5\}$  represent the set of valuations  $v$  such that  $v(x) \leq 3$ ,  $v(y) \geq 4$  and  $v(x) - v(y) < -5$ .

**Lemma 2.** *Let  $f$  be a function defined on a bounded zone  $Z \subset \mathbb{R}^n$  (where  $n \geq 1$ ) by*

$$f(x_1, \dots, x_n) = \frac{\sum_{i=1}^n c_i x_i + c}{\sum_{i=1}^n r_i x_i + r}$$

*We assume in addition that  $\overline{Z}$  (the closure of  $Z$  for the usual topology) is included in the definition set of  $f$ . Then the infimum of  $f$  on  $Z$  is obtained on a point of  $\overline{Z}$  with integer coordinates.*

The two lemmas above together imply that the infimum of such a function  $f$  on a bounded zone  $Z$  is obtained in one of the corner-points of the zone. The result could be easily generalized to general bounded convex polyhedra, and not only bounded zones. The result would then be that the function  $f$  is minimized in one of the corner-points of the polyhedron, a corner-point representing intuitively an extremal point .

## 6 Soundness of the Corner-Point Abstraction

The aim of this section is to prove that the corner-point abstraction is sound, that is for all the infinite paths in the timed automaton, we can find an infinite path in the corner-point abstract automaton with a smaller ratio. The proof will be done in two steps: first, we will consider **finite** paths, and then we will extend the result to **infinite** paths.

**Theorem 2.** *Let  $\mathcal{A}$  be a bounded, strongly reward-diverging DPTA with non-negative rewards. Then,  $\mu_{\mathcal{A}_{cp}}^* \leq \mu_{\mathcal{A}}^*$ .*

<sup>7</sup> Note that  $\|\cdot\|_\infty$  denotes the infinite norm in every dimension.

**Considering finite paths.**

**Proposition 3.** *Let  $\mathcal{A}$  be a bounded, strongly reward-diverging DPTA and let  $\gamma$  be a finite execution in  $\mathcal{A}$ . Then there exists an execution  $\pi \in \text{proj}_{\text{cp}}(\gamma)$  such that*

$$\text{Ratio}(\pi) \leq \text{Ratio}(\gamma) .$$

The special case where the reward is impulse-based may be obtained as a direct consequence of previous works on cost-optimality in timed automata (cf for example [BFH<sup>+</sup>01b,BFH<sup>+</sup>01a,LBB<sup>+</sup>01]). The general case however requires a new proof. It will require the technical results developed in section 5.

*Proof.* Let  $\gamma = (\ell_0, u_0) \longrightarrow (\ell_0, u_0 + d_0) \longrightarrow (\ell_1, u_1) \longrightarrow (\ell_1, u_1 + d_1) \cdots \longrightarrow (\ell_n, u_n)$  be a finite execution in  $\mathcal{A}$  (with alternating delay and discrete transitions). We set for any  $1 \leq i \leq n$ ,  $t_i = \sum_{0 \leq j < i} d_j$ . We moreover assume that this execution is read on the sequence of transitions  $\ell_0 \xrightarrow{g_1, C_1} \ell_1 \cdots \xrightarrow{g_n, C_n} \ell_n$  in  $\mathcal{A}$ . The ratio of  $\gamma$  is:

$$f(t_1, \dots, t_n) = \frac{\sum_{i=1}^n c_i(t_i - t_{i-1}) + c}{\sum_{i=1}^n r_i(t_i - t_{i-1}) + r}$$

where  $c_i, r_i$  are the cost and reward of the transition  $\ell_{i-1} \xrightarrow{g_i, C_i} \ell_i$  and  $c, r$  are the sum of all the discrete costs and rewards along  $\gamma$ .

We want to minimize this function with the constraints that for all  $i, v'_i \in R_i$  where:

- $v'_i(x) = t_i - t_j$  where  $j = \max\{k \leq i \mid x \in C_k\}$
- $R_i$  is the region to which belongs  $v_i$

The set of constraints  $\{v'_i \in R_i \mid i = 1..n\}$  defines a zone  $Z$  on the variables  $(t_i)_{i=1..n}$ . We can apply Lemma 2 and we get that the infimum of  $f$  on  $Z$  is obtained in (at least) a point with integer coordinates, say  $(\alpha_i)_{i=1..n}$ . Note that this point is in the closure of  $Z$ , and thus that it satisfies in particular the set of constraints  $\{v'_i \in \overline{R_i} \mid i = 1..n\}$ .

We define the valuations  $(\sigma_i)_{i=1..n}$  by  $\sigma_i(x) = \alpha_i - \alpha_j$  where  $j = \max\{k \leq i \mid x \in C_k\}$ . Each valuation  $\sigma_i$  is in  $\overline{R_i}$  and has integer coordinates. It is thus a corner-point of  $R_i$ . Moreover, the sequence of valuations  $(\sigma_i)_i$  would be an accepted sequence if we replace the constraints  $R_i$  by  $\overline{R_i}$ . In addition, the time elapsed in each state  $\ell_i$  would then be  $\alpha_{i+1} - \alpha_i$ .

It is now easy to build a path  $\pi$  in  $\text{proj}_{\text{cp}}(\gamma)$  (see associated research report) which goes through the states  $(\ell_i, \alpha_{i+1} - \alpha_i)$  and whose ratio is:

$$\text{Ratio}(\pi) = \frac{\sum_{i=1}^n c_i(\alpha_i - \alpha_{i-1}) + c}{\sum_{i=1}^n r_i(\alpha_i - \alpha_{i-1}) + r}$$

We thus get that  $\text{Ratio}(\pi) \leq \text{Ratio}(\gamma)$  and we are done.  $\square$

**Extension to Infinite Paths.** We will now prove that the previous property, restricted to finite executions, can be extended to infinite executions.

**Proposition 4.** *Let  $\mathcal{A}$  be a bounded, strictly reward-diverging DPTA with non-negative rewards, and let  $\Gamma$  be a **non-zeno** infinite real path in  $\mathcal{A}$ . Then, there exists an infinite path  $\Pi$  in  $\mathcal{A}_{\text{cp}}$  such that*

$$\text{Ratio}(\Pi) \leq \underline{\text{Ratio}}(\Gamma) . \quad (\star)$$

Notice that, on the contrary to Proposition 3 the path  $\Pi$  may not be in  $\text{proj}_{\text{cp}}(\Gamma)$ . In addition, for any finite prefix  $\gamma$  of  $\Gamma$ , it may happen that no finite prefix of  $\Pi$  satisfies the property described in Proposition 3, which means that we will not solve the problem just by extending paths given by Proposition 3.

*Proof.* Let  $\Gamma : (\ell_0, u_0) \longrightarrow (\ell_1, u_1) \dots$  be an infinite path in  $\mathcal{A}$ . In the following, we will denote by  $\Gamma_n$  the prefix of length  $n$  of  $\Gamma$ .

Let  $\alpha$  be the value of the minimal ratio for a reachable cycle in  $\mathcal{A}_{\text{cp}}$ . Let  $n$  be an integer. From Proposition 3, there exists a path  $\Pi_n$  in  $\text{proj}_{\text{cp}}(\Gamma_n)$  such that  $\text{Ratio}(\Pi_n) \leq \text{Ratio}(\Gamma_n)$ . Using Proposition 2, we get that  $\text{Reward}(\Pi_n) \in \Omega(n)$ , which implies in particular that  $\lim_{n \rightarrow +\infty} \text{Reward}(\Pi_n) = +\infty$ .

We decompose  $\Pi_n$  into cycles, *i.e.* we write  $\Pi_n = \pi_{0,n} \cdot C_{1,n} \cdot \pi_{1,n} \dots C_{p_n,n} \cdot \pi_{p_n,n}$  where  $\pi_{i,n}$  are simple paths and  $C_{i,n}$  are cycles. We assume in addition that this decomposition is maximal in the sense that the path  $\pi_{0,n} \cdot \pi_{1,n} \dots \pi_{p_n,n}$  is acyclic. The maximality property of our decomposition implies that the total length of  $\pi_{0,n} \cdot \pi_{1,n} \dots \pi_{p_n,n}$  is less than the number of nodes in  $\mathcal{A}_{\text{cp}}$ .

We set  $C(n) = \sum_{i=0}^{p_n} \text{Cost}(\pi_{i,n})$  and  $R(n) = \sum_{i=0}^{p_n} \text{Reward}(\pi_{i,n})$  and we compute now the difference between  $\text{Ratio}(\Pi_n)$  and  $\alpha$ :

$$\begin{aligned} \text{Ratio}(\Pi_n) - \alpha &= \frac{\sum_{i=1}^{p_n} \text{Cost}(C_{i,n}) + C(n)}{\sum_{i=1}^{p_n} \text{Reward}(C_{i,n}) + R(n)} - \alpha \\ &= \frac{\sum_{i=1}^{p_n} \text{Cost}(C_{i,n})}{\sum_{i=1}^{p_n} \text{Reward}(C_{i,n})} + \frac{C(n)}{\sum_{i=1}^{p_n} \text{Reward}(C_{i,n})} - \alpha \\ &= \frac{C(n)}{1 + \frac{R(n)}{\sum_{i=1}^{p_n} \text{Reward}(C_{i,n})}} - \alpha \end{aligned}$$

We set  $\beta(n) = \frac{\sum_{i=1}^{p_n} \text{Cost}(C_{i,n})}{\sum_{i=1}^{p_n} \text{Reward}(C_{i,n})}$  and we have that  $\beta(n) \geq \alpha$  because  $\alpha$  is the ratio of the minimal reachable cycle.<sup>8</sup> We get that

$$\text{Ratio}(\Gamma_n) - \alpha \geq \text{Ratio}(\Pi_n) - \alpha = \frac{\beta(n) - \alpha + \frac{C(n) - \alpha R(n)}{\sum_{i=1}^{p_n} \text{Reward}(C_{i,n})}}{1 + \frac{R(n)}{\sum_{i=1}^{p_n} \text{Reward}(C_{i,n})}} \quad (\star\star)$$

Observe now that  $R(n)$  and  $C(n)$  are bounded and that  $\lim_{n \rightarrow +\infty} \sum_{i=0}^{p_n} \text{Reward}(C_{i,n}) = +\infty$ . We can now take the infimum limit of Equation  $(\star\star)$ , and we get:

$$\underline{\lim}_{n \rightarrow +\infty} (\text{Ratio}(\Gamma_n)) - \alpha \geq \underline{\lim}_{n \rightarrow +\infty} \beta(n) - \alpha \geq 0$$

Hence, the infimum ratio of  $\Gamma$  is greater than the ratio of the optimal reachable cycle in  $\mathcal{A}_{\text{cp}}$ .  $\square$

<sup>8</sup> Remind the property that if  $b > 0$  and  $d > 0$ , then  $\min(\frac{a}{b}, \frac{c}{d}) \leq \frac{a+c}{b+d} \leq \max(\frac{a}{b}, \frac{c}{d})$ .

## 7 Completeness of the Corner-Point Abstraction

The aim of this section is to state the completeness of the corner-point abstraction. More precisely, we will prove that for every infinite path of the corner-point abstraction, there are real paths in the original automaton whose ratio is as close as we want to the ratio of the given path in the corner-point abstraction.

**Theorem 3.** *Let  $\mathcal{A}$  be a bounded, strongly reward-diverging DPTA with non-negative rewards. Then,  $\mu_{\mathcal{A}}^* \leq \mu_{\mathcal{A}_{\text{cp}}}^*$ .*

The proof of this theorem will be done in two steps: we will first prove that we can approximate paths in  $\mathcal{A}_{\text{cp}}$  by paths in  $\mathcal{A}$  which are as close as we want to the original path (proposition 5). It will be sufficient to prove that for each infinite path in  $\mathcal{A}_{\text{cp}}$ , under the strongly reward-divergence assumptions, we can find a real path in  $\mathcal{A}$  whose ratio is as close as we want to the ratio of the given path in  $\mathcal{A}_{\text{cp}}$  (proposition 6).

**Proposition 5.** *Let  $\mathcal{A}$  be a bounded DPTA. Let  $\pi : (\ell_0, R_0, \alpha_0) \rightarrow \dots (\ell_n, R_n, \alpha_n) \dots$  be a (possibly infinite) path in  $\mathcal{A}_{\text{cp}}$ . Let  $0 < \varepsilon < \frac{1}{2}$ . There exists a real path  $\gamma_\varepsilon : (\ell_0, u_0) \rightarrow \dots (\ell_n, u_n) \dots$  in  $\mathcal{A}$  such that  $u_i \in R_i$  and  $\|u_i - \alpha_i\|_\infty < \varepsilon$  for every  $i$ <sup>9</sup>.*

*Proof.* Let  $v$  be a valuation. For any clock  $x$ , we define  $\mu_v(x) = \min\{|v(x) - p| \mid p \text{ integer}\}$  and for any pair of clocks  $(x, y)$ ,  $\nu_v(x, y) = \min\{|v(x) - v(y) - p| \mid p \text{ integer}\}$ . We define the *diameter* of  $v$  as

$$\delta(v) = \max(\{\mu_v(x) \mid x \text{ clock}\} \cup \{\nu_v(x, y) \mid x, y \text{ clocks}\})$$

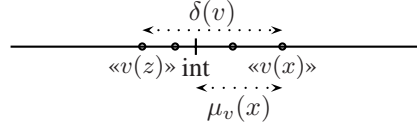

Proposition 5 will be a direct consequence of the following technical lemma.

**Lemma 3.** *Consider a transition  $(\ell, R, \alpha) \rightarrow (\ell', R', \alpha')$  in  $\mathcal{A}_{\text{cp}}$ , take a valuation  $v \in R$  such that  $\delta(v) < \varepsilon$  and  $|v(x) - \alpha(x)| = \mu_v(x)$ . There exists a valuation  $v' \in R'$  such that  $(\ell, v) \rightarrow (\ell', v')$  in  $\mathcal{A}$ ,  $\delta(v') < \varepsilon$  and  $|v'(x) - \alpha'(x)| = \mu_{v'}(x)$ .*

Using this lemma, we construct inductively a path  $\gamma_\varepsilon$  as described above, at each step of the construction we have that  $\|v_i - \alpha_i\|_\infty \leq \delta(v_i)$ . This concludes the proof.  $\square$

We now use this result on paths to prove the following proposition on ratios.

**Proposition 6.** *Let  $\mathcal{A}$  be a bounded, strongly reward-diverging DPTA with non-negative rewards. Let  $\Pi$  be an infinite path in  $\mathcal{A}_{\text{cp}}$  such that  $\text{Ratio}(\Pi)$  is defined. Then the following holds: for any  $\varepsilon > 0$ , there exists a real path  $\Gamma^\varepsilon$  such that defined and  $|\text{Ratio}(\Pi) - \text{Ratio}(\Gamma^\varepsilon)| < \varepsilon$ .*

Note that in case we have only non-strict constraints along the path accepting  $\Gamma$  in  $\mathcal{A}$ ,  $\Pi$  corresponds to a real path in  $\mathcal{A}$ , it thus corresponds to  $\Gamma_{\mathcal{A}}^*$ . Otherwise, the paths constructed in the following will give us a family  $(\Gamma_{\mathcal{A}}^{*,\varepsilon})_{\varepsilon>0}$  of optimal schedules.

Note also that in  $\mathcal{A}_{\text{cp}}$  (which is a finite automaton), optimal schedules are cycles for which the ratio is defined [Kar78,DG98,DIG99]. The previous proposition thus proves the completeness of the corner-point abstraction and concludes this section.

<sup>9</sup>  $\|\cdot\|_\infty$  represents the usual infinite norm defined as  $\|(x_i)_{i=1..n}\|_\infty = \max\{|x_i| \mid i = 1..n\}$ .

## 8 Future Work and Conclusion

In this paper, we have shown that the optimal infinite scheduling problem is computable for double-priced timed automata (and PSPACE-complete, see [BBL04]). We have reduced the problem to the computation of optimal infinite schedules in (weighted) finite-state graphs. This problem is equivalent to finding optimal cycles in finite-state graphs, which can be done using algorithms like Karp's algorithm [Kar78] and some of its extensions and improvements [DG98,DIG99].

However, there is still a number of issues which are open for future work. The proof of computability, based on regions and corner-points, does not provide a realistic implementation strategy. We would like to obtain an efficient implementation based on zones and on-the-fly exploration of the symbolic state-space. A restriction to a setting where one of the prices (cost or reward) is uniform (same rate in all locations) may be particularly useful. Implementations for this specific case could be much more efficient than those for the general problem. An idea would then be to approximate optimal infinite schedules by working with (repeated) cost horizons or by applying partitioning and refinement techniques, as done in the tool Rapture [DJLL01,DJLL02].

An extension of our present work would be to address the problem in the presence of adversaries, even if it seems very difficult, more difficult than that of cost-optimal winning strategies for (single-)priced timed automata with adversaries [LTMM02]. In the finite-state setting, however, the problem has been solved [ZP96].

## References

- [AC91] D. Applegate and W. Cook. *A Computational Study of the Job-Shop Scheduling Problem*. OSRA Journal on Computing, vol. 3:pp. 149–156, 1991.
- [AD90] R. Alur and D. Dill. *Automata for Modeling Real-Time Systems*. In Proc. 17th Int. Coll. Automata, Languages and Programming (ICALP'90), vol. 443 of LNCS, pp. 322–335. Springer, 1990.
- [AD94] R. Alur and D. Dill. *A Theory of Timed Automata*. Theoretical Computer Science (TCS), vol. 126(2):pp. 183–235, 1994.
- [ALTP01] R. Alur, S. La Torre, and G. J. Pappas. *Optimal Paths in Weighted Timed Automata*. In Proc. 4th Int. Work. Hybrid Systems: Computation and Control (HSCC'01), vol. 2034 of LNCS, pp. 49–62. Springer, 2001.
- [AM99] E. Asarin and O. Maler. *As Soon as Possible: Time Optimal Control for Timed Automata*. In Proc. 2nd Int. Work. Hybrid Systems: Computation and Control (HSCC'99), vol. 1569 of LNCS, pp. 19–30. Springer, 1999.
- [AM01] Y. Abdeddaim and O. Maler. *Job-Shop Scheduling using Timed Automata*. In Proc. 13th Int. Conf. Computer Aided Verification (CAV'01), vol. 2102 of LNCS, pp. 478–492. Springer, 2001.
- [AM02] Y. Abdeddaim and O. Maler. *Preemptive Job-Shop Scheduling using Stopwatch Automata*. In Proc. 8th Int. Conf. Tools and Algorithms for the Construction and Analysis of Systems (TACAS'02), vol. 2280 of LNCS, pp. 113–126. Springer, 2002.
- [BBL04] P. Bouyer, E. Brinksma, and K. G. Larsen. *Staying Alive as Cheaply as Possible*. Research Report LSV-04-2, LSV, ENS de Cachan, France, 2004.
- [BFH<sup>+</sup>01a] G. Behrmann, A. Fehnker, T. Hune, K. G. Larsen, P. Pettersson, J. Romijn, and F. Vaandrager. *Efficient Guiding Towards Cost-Optimality in UPPAAL*. In Proc.

- 7th Int. Conf. Tools and Algorithms for the Construction and Analysis of Systems (TACAS'01), vol. 2031 of LNCS, pp. 174–188. Springer, 2001.
- [BFH<sup>+</sup>01b] G. Behrmann, A. Fehnker, T. Hune, K. G. Larsen, P. Pettersson, J. Romijn, and F. Vaandrager. *Minimum-Cost Reachability for Priced Timed Automata*. In Proc. 4th Int. Work. Hybrid Systems: Computation and Control (HSCC'01), vol. 2034 of LNCS, pp. 147–161. Springer, 2001.
- [BLL<sup>+</sup>98] J. Bengtsson, K. G. Larsen, F. Larsson, P. Pettersson, W. Yi, and C. Weise. *New Generation of UPPAAL*. In Proc. Int. Work. Software Tools for Technology Transfer (STTT'98), BRICS Notes Series, pp. 43–52. 1998.
- [BMF02] E. Brinksma, A. Mader, and A. Fehnker. *Verification and Optimization of a PLC Control Schedule*. Journal of Software Tools for Technology Transfer (STTT), vol. 4(1):pp. 21–33, 2002.
- [DG98] A. Dasdan and R. K. Gupta. *Faster Maximum and Minimum Mean Cycle Algorithms for System Performance Analysis*. IEEE Transactions on Computer-Aided Design of Integrated Circuits and Systems, vol. 17(10):pp. 889–899, 1998.
- [DIG99] A. Dasdan, S. Irani, and R. K. Gupta. *Efficient Algorithms for Optimum Cycle Mean and Optimum Cost to Time Ratio Problems*. In Proc. 36th ACM/IEEE Design Automation Conf. (DAC'99), pp. 47–42. ACM, 1999.
- [DJJL01] P. R. D'Argenio, B. Jeannet, H. E. Jensen, and K. G. Larsen. *Reachability Analysis of Probabilistic Systems by Successive Refinements*. In Proc. 1st Int. Work. Process Algebra and Probabilistic Methods, Performance Modeling and Verification (PAPM-PROBMIV'01), vol. 2165 of LNCS, pp. 39–56. Springer, 2001.
- [DJJL02] P. R. D'Argenio, B. Jeannet, H. E. Jensen, and K. G. Larsen. *Reduction and Refinement Strategies for Probabilistic Analysis*. In Proc. 2nd Int. Work. Process Algebra and Probabilistic Methods, Performance Modeling and Verification (PAPM-PROBMIV'02), vol. 2399 of LNCS, pp. 57–76. Springer, 2002.
- [Feh99] A. Fehnker. *Scheduling a Steel Plant with Timed Automata*. In Proc. 6th Int. Conf. Real-Time Computing Systems and Applications (RTCSA'99), pp. 280–286. IEEE Computer Society Press, 1999.
- [HLP00] T. Hune, K. G. Larsen, and P. Pettersson. *Guided Synthesis of Control Programs Using UPPAAL*. In Proc. IEEE ICDS Int. Work. Distributed Systems Verification and Validation, pp. E15–E22. IEEE Computer Society Press, 2000.
- [Kar78] R. M. Karp. *A Characterization of the Minimum Mean-Cycle in a Digraph*. Discrete Mathematics, vol. 23(3):pp. 309–311, 1978.
- [LBB<sup>+</sup>01] K. G. Larsen, G. Behrmann, E. Brinksma, A. Fehnker, T. Hune, P. Pettersson, and J. Romijn. *As Cheap as Possible: Efficient Cost-Optimal Reachability for Priced Timed Automata*. In Proc. 13th Int. Conf. Computer Aided Verification (CAV'01), vol. 2102 of LNCS, pp. 493–505. Springer, 2001.
- [LPY97] K. G. Larsen, P. Pettersson, and W. Yi. *UPPAAL in a Nutshell*. Journal of Software Tools for Technology Transfer (STTT), vol. 1(1–2):pp. 134–152, 1997.
- [LTMM02] S. La Torre, S. Mukhopadhyay, and A. Murano. *Optimal-Reachability and Control for Acyclic Weighted Timed Automata*. In Proc. 2nd IFIP Int. Conf. Theoretical Computer Science (TCS 2002), vol. 223 of IFIP Conf. Proc., pp. 485–497. Kluwer, 2002.
- [Mad03] A. Mader. *Deriving Schedules for a Smart Card Personalisation System*, 2003. Submitted.
- [NY01] P. Niebert and S. Yovine. *Computing Efficient Operations Schemes for Chemical Plants in Multi-batch Mode*. European Journal of Control, vol. 7(4):pp. 440–453, 2001.
- [ZP96] U. Zwick and M. Paterson. *The Complexity of Mean Payoff Games on Graphs*. Theoretical Computer Science (TCS), vol. 158(1–2):pp. 343–359, 1996.